

RoHS

5	6	7	8
ECN NO.	REV	DATE	DESCRIPTION

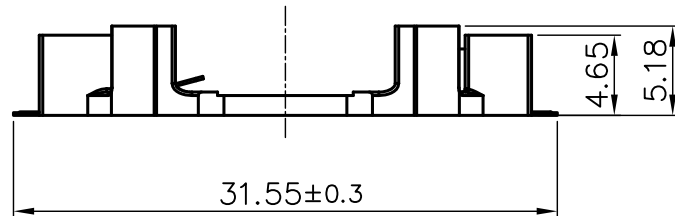
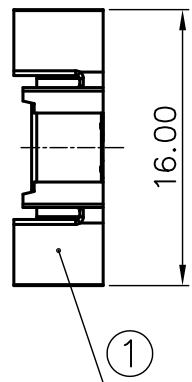
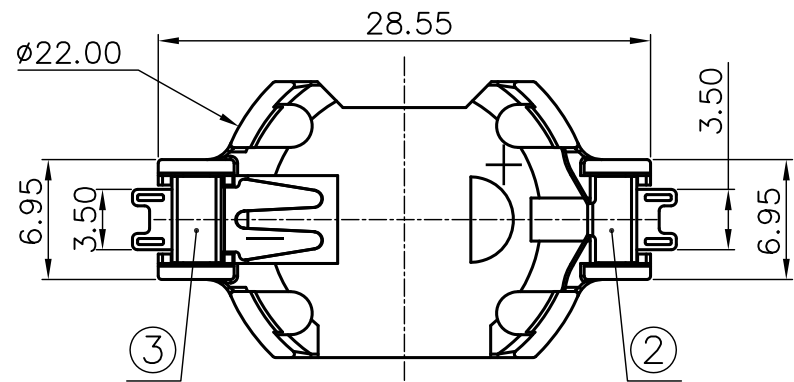

NOTE:

- 1.MATERIAL:
  - a.HOUSING:PPA WHITE
  - b.CONTACT:PHOSPHOR BRONZE  
(SURFACE PLATING: Sn100U"~120U"")  
SEE ORDERING INFORMATION
- 2.ELECTRIC:
  - a.CONTACT RESISTANCE: 50 MILLIOHMS MAX
  - b.INSULATION RESISTANCE: 100 MEGA OHMS MIN
  - c.DIELECTNIC VOLTAGE: 500V AC ONE SEC LEVEL
  - d.OPERATING TEMPERATURE: -25°C~ +85°C

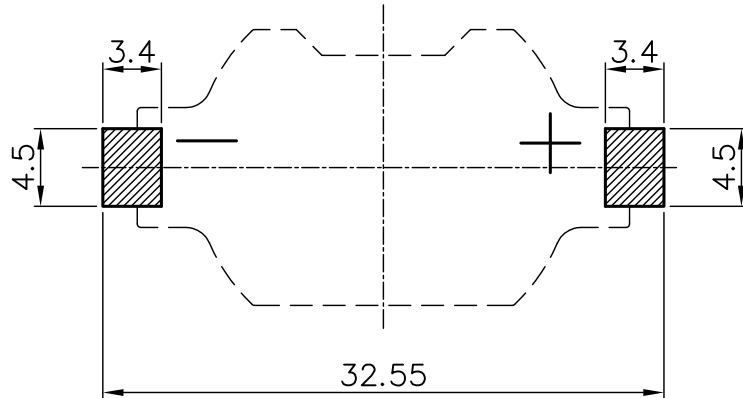

PCB Layout Diagram  
Top View

③	TERMINAL(-)	1	PHOSPHOR BRONZE, T=0.20mm	Sn Plating
②	TERMINAL(+)	1	PHOSPHOR BRONZE, T=0.20mm	Sn Plating
①	HOUSING	1	PPA	WHITE
NO.	PART NAME	Q'TY	MATERIAL	PLATING & COLOR

UNLESS OTHERWISE SPECIFIED TOLERANCES				MeiYang Electronics Co.Ltd			
DECIMALS:	ANGLES:	DSND	DATE	TITLE:			
X :±0.30	X :±1°	CHKD	DATE	BS-2032-6-2 PPA Sn			
X.X :±0.25	X.X :±0.5°	APVD	DATE	PART NO.:			
X.XX :±0.20	X.XXX:±0.10	WEIGHT:1.02g	SCALE:2:1	SIZE:A4	VIEW:	BS-06-B2CK***	
SHEET 1 OF 1			UNIT:mm	REV.:A/0	OBJECT:MY	DRAW NO.:MY-CP-****	