

RoHS

5	6	7	8
ECN NO.	REV	DATE	DESCRIPTION

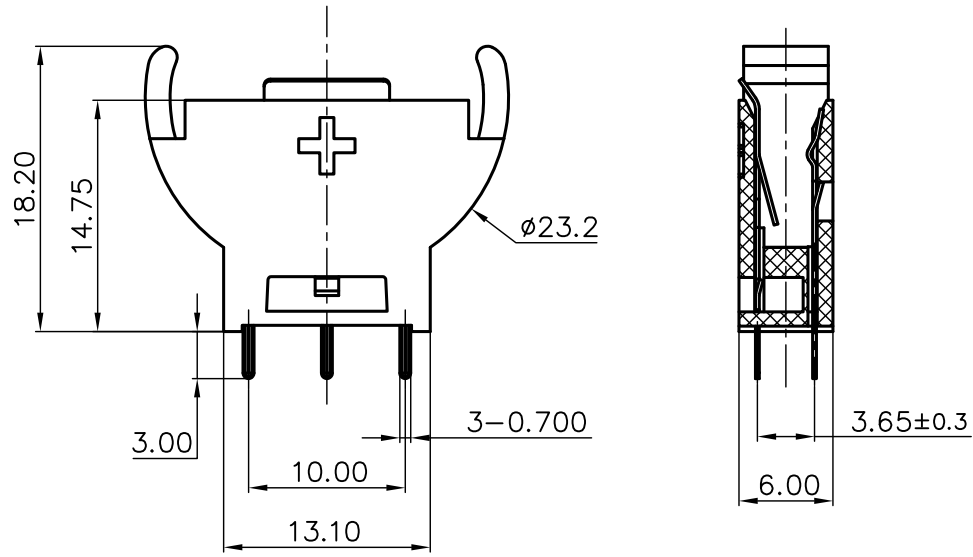

NOTE:
 1.MATERIAL:
 a.HOUSING:PA66
 b.CONTACT:BRASS
 (SURFACE PLATING: Ni 100u"-120u")
 2.ELECTRIC:
 a.CONTACT RESISTANCE: 30 MILLIOHMS MAX
 b.INSULATION RESISTANCE: 100 MEGA OHMS MIN
 c.DIELECTNIC VOLTAGE: 500V AC ONE SEC LEVEL
 d.OPERATING TEMPERATURE: -25°C~ +85°C

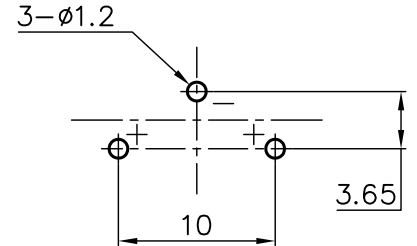
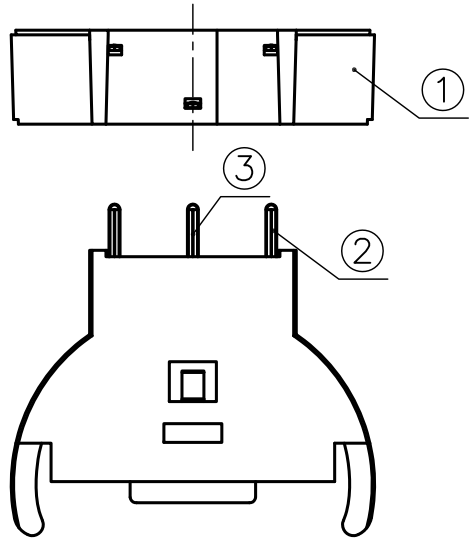

PCB Layout Diagram
Top View

NO.	PART NAME	Q'TY	MATERIAL	PLATING & COLOR
③	TERMINAL(-)	1	BRASS, T=0.25mm	Ni Plating
②	TERMINAL(+)	1	BRASS, T=0.25mm	Ni Plating
①	HOUSING	1	PA66	BLACK

UNLESS OTHERWISE SPECIFIED TOLERANCES		MeiYang Electronics Co.Ltd			
DECIMALS:	ANGLES:	DSND	DATE	TITLE:	
X :±0.30	X :±1°	CHKD	DATE	BS-2032-5	
X.X :±0.25	X.X:±0.5°	APVD	DATE	PART NO.:	
X.XX :±0.20		WEIGHT:1.64g	SCALE:2:1	SIZE:A4	VIEW:
X.XXX:±0.10		SHEET 1 OF 1	UNIT:mm	REV.:A/0	DRAW NO.:MY-CP-0023

