

RoHS

ECN NO.	REV	DATE	DESCRIPTION	CHANGE	CHECK	APPRO

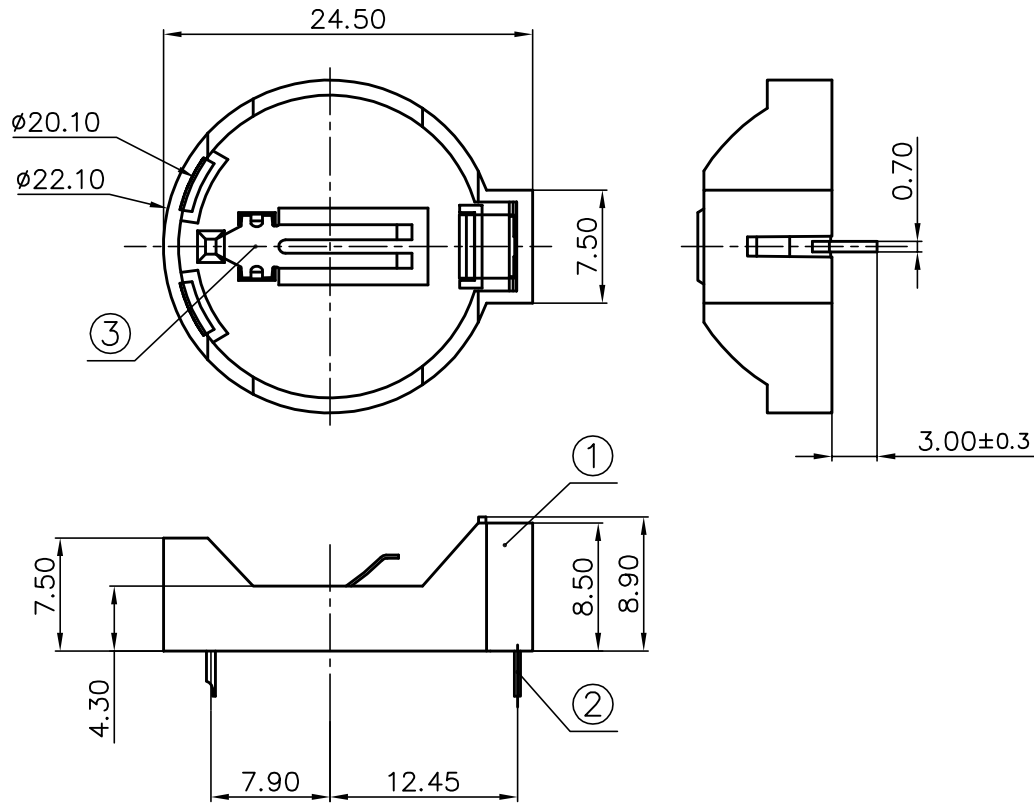

NOTE:

1.MATERIAL:

- a.HOUSING:PBT
- b.CONTACT:PHOSPHOR BRONZE  
(SURFACE PLATING: Sn 100u"-120u")

2.ELECTRIC:

- a.CONTACT RESISTANCE: 30 MILLIOHMS MAX
- b.INSULATION RESISTANCE: 1000 MEGA OHMS MIN
- c.DIELECTNIC VOLTAGE: 500V AC ONE SEC LEVEL
- d.OPERATING TEMPERATURE: -25°C~ +85°C

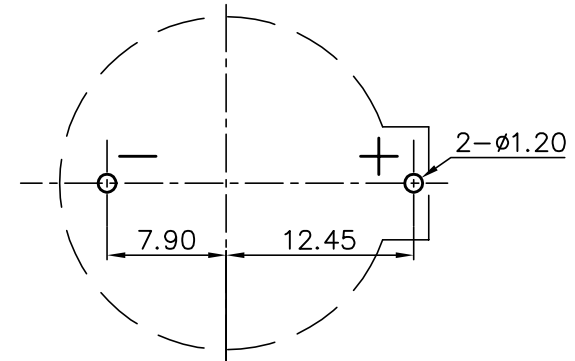

③	TERMINAL(-)	1	PHOSPHOR BRONZE,T=0.2mm	Sn Plating
②	TERMINAL(+)	1	PHOSPHOR BRONZE,T=0.4mm	Sn Plating
①	HOUSING	1	PBT	BLACK
NO.	PART NAME	Q'TY	MATERIAL	PLATING & COLOR

UNLESS OTHERWISE SPECIFIED TOLERANCES  
 X :±0.30X :±1°  
 X.X :±0.25 X.X:±0.5°  
 X.XX :±0.20  
 X.XXX:±0.10

MeiYang Electronics Co.Ltd

DSND	LQ.HUANG	DATE	2018-05-12	TITLE:	BS-2032-2-1
CHKD		DATE			
APVD	XY.XUE	DATE	2018-05-12	PART NO.:	BS-02-A1AK006
WEIGHT:1.56g	SCALE:2:1	SIZE:A4	VIEW:		
SHEET 1 OF 1	UNIT:mm	REV.:A/0	OBJECT:MY	DRAW NO.:MY-CP-0026	