

RoHS

5	6	7	8
ECN NO.	REV	DATE	DESCRIPTION

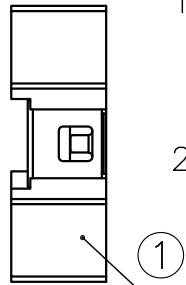
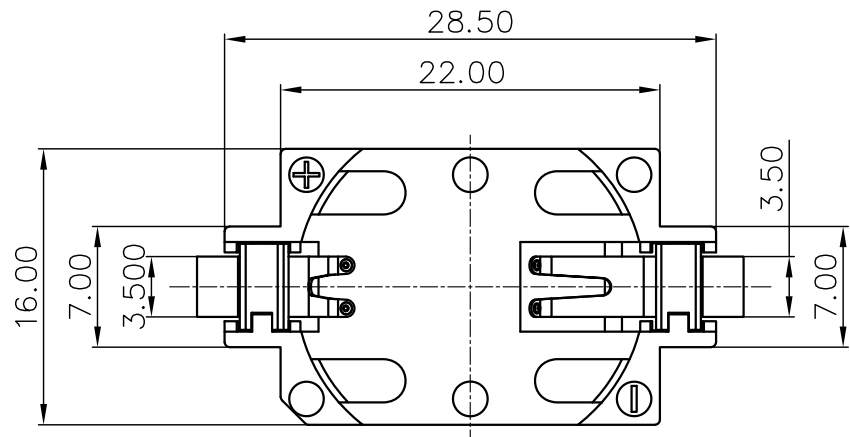

NOTE:

- 1.MATERIAL:
 - a.HOUSING:LCP
 - b.CONTACT:PHOSPHOR BRONZE
(SURFACE PLATING:Sn100u"-120u")
- 2.ELECTRIC:
 - a.CONTACT RESISTANCE: 30 MILLIOHMS MAX
 - b.INSULATION RESISTANCE: 1000 MEGA OHMS MIN
 - c.DIELECTNIC VOLTAGE: 500V AC ONE SEC LEVEL
 - d.OPERATING TEMPERATURE: -25°C~ +85°C

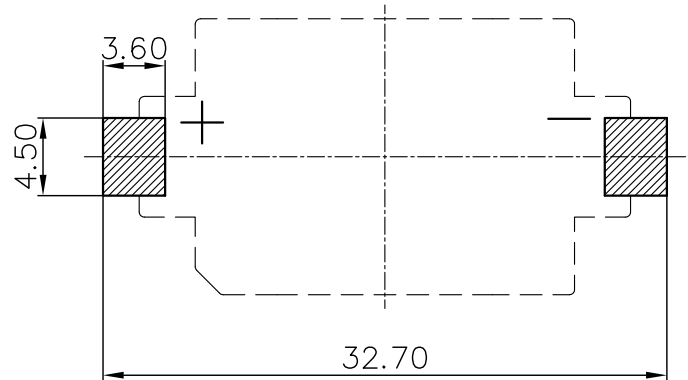
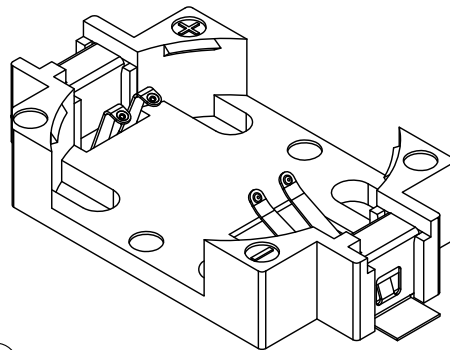
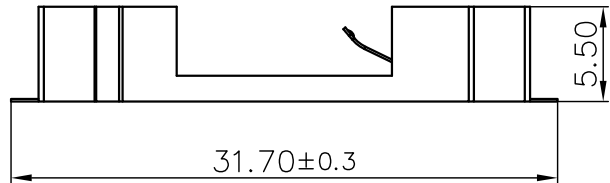

PCB Layout Diagram
Top View

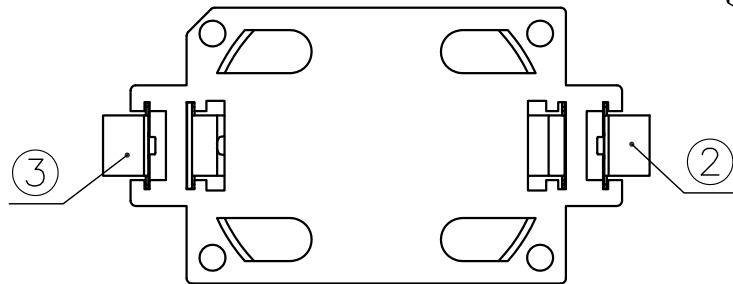

UNLESS OTHERWISE SPECIFIED TOLERANCES				MeiYang Electronics Co.Ltd			
DECIMALS: X :±0.30 X.X :±0.25 X.XX :±0.20 X.XXX:±0.10		ANGLES: X :±1° X.X :±0.5°		DSND	LQ.HUANG	DATE	2018-05-04
				CHKD		DATE	
				APVD	XY.XUE	DATE	2018-05-04
WEIGHT:				SCALE:	SIZE:A4	VIEW:	⊙ ⊚
SHEET 1 OF 1				UNIT:mm	REV.:A/0	OBJECT:MY	DRAW NO.:MY-CP-0013
				TITLE: BS-2032-6 Sn SMT			
				PART NO.: BS-06-B4AK001			

NO.	PART NAME	Q'TY	MATERIAL	PLATING & COLOR
③	TERMINAL(-)	1	PHOSPHOR BRONZE, T=0.15mm	Sn Plating
②	TERMINAL(+)	1	PHOSPHOR BRONZE, T=0.15mm	Sn Plating
①	HOUSING	1	LCP	WHITE