

RoHS

| 5       | 6   | 7    | 8           |
|---------|-----|------|-------------|
| ECN NO. | REV | DATE | DESCRIPTION |
|         |     |      |             |
|         |     |      |             |
|         |     |      |             |

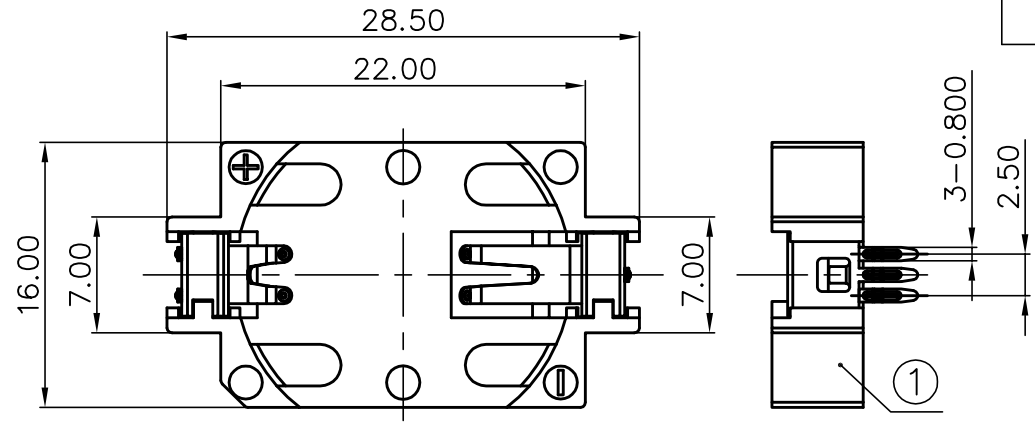

NOTE:  
 1.MATERIAL:  
 a.HOUSING:LCP  
 b.CONTACT:PHOSPHOR BRONZE  
 (SURFACE PLATING:Sn100u"-120u")  
 2.ELECTRIC:  
 a.CONTACT RESISTANCE: 30 MILLIOHMS MAX  
 b.INSULATION RESISTANCE: 1000 MEGA OHMS MIN  
 c.DIELECTNIC VOLTAGE: 500V AC ONE SEC LEVEL  
 d.OPERATING TEMPERATURE: -25°C~ +85°C

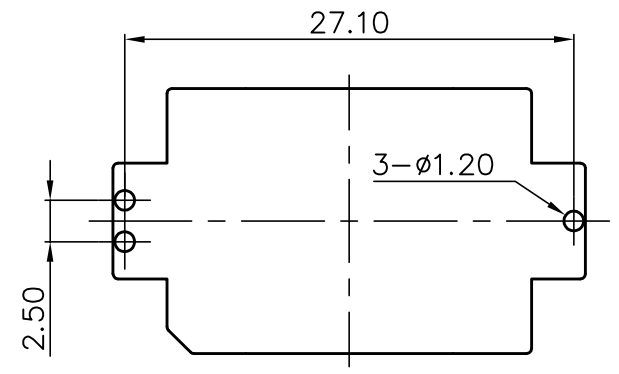
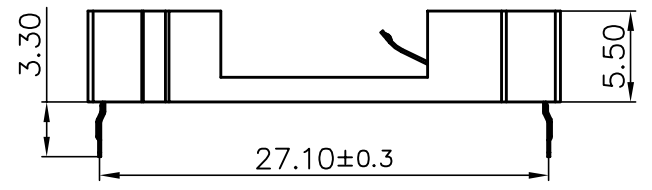

PCB Layout Diagram  
Top View

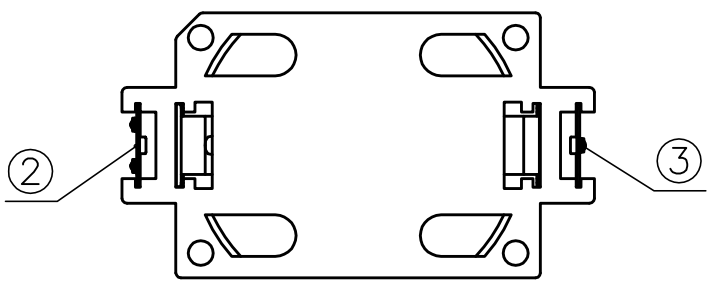

|                                       |           |                            |           |               |                     |
|---------------------------------------|-----------|----------------------------|-----------|---------------|---------------------|
| UNLESS OTHERWISE SPECIFIED TOLERANCES |           | MeiYang Electronics Co.Ltd |           |               |                     |
| DECIMALS:                             | ANGLES:   | DSND                       | DATE      | TITLE:        |                     |
| X :±0.30                              | X :±1°    | CHKD                       | DATE      | BS-2032-6 DIP |                     |
| X.X :±0.25                            | X.X:±0.5° | APVD                       | DATE      | PART NO.:     |                     |
| X.XX :±0.20                           |           |                            |           | BS-06-A4AK003 |                     |
| X.XXX:±0.10                           |           | WEIGHT:1.49g               | SCALE:2:1 | SIZE:A4       | VIEW:               |
|                                       |           | SHEET 1 OF 1               | UNIT:mm   | REV.:A/0      | OBJECT:MY           |
|                                       |           |                            |           |               | DRAW NO.:MY-CP-0010 |

| NO. | PART NAME   | Q'TY | MATERIAL                  | PLATING & COLOR |
|-----|-------------|------|---------------------------|-----------------|
| ③   | TERMINAL(-) | 1    | PHOSPHOR BRONZE, T=0.15mm | Sn Plating      |
| ②   | TERMINAL(+) | 1    | PHOSPHOR BRONZE, T=0.15mm | Sn Plating      |
| ①   | HOUSING     | 1    | LCP                       | WHITE           |